

# TST TAI-SAW TECHNOLOGY CO., LTD.

No. 3, Industrial 2nd Rd., Ping-Chen Industrial District,  
Taoyuan, 324, Taiwan, R.O.C.

TEL: 886-3-4690038 FAX: 886-3-4697532

E-mail: [tstsales@mail.taisaw.com](mailto:tstsales@mail.taisaw.com) Web: [www.taisaw.com](http://www.taisaw.com)

## Product Specifications Approval Sheet

Product Description: SAW Resonator 644.873 MHz SMD 3.0X3.0 mm

TST Part No.: TC0532A

Customer Part No.: \_\_\_\_\_

Customer signature required
Company: _____
Division: _____
Approved by : _____
Date: _____

Checked by: \_\_\_\_\_ Hongpu Lin *Hong Pu Lin*

Approval by: \_\_\_\_\_ Andy Yu *Andy Yu*

Date: \_\_\_\_\_ 2019/04/25

1. Customer signed back is required before TST can proceed with sample build and receive orders.
2. Orders received without customer signed back will be regarded as agreement on the specifications.
3. Any specifications changes must be approved upon by both parties and a new revision of specifications shall be released to reflect the changes.



# TAI-SAW TECHNOLOGY CO., LTD.

No. 3, Industrial 2nd Rd., Ping-Chen Industrial District,  
Taoyuan, 324, Taiwan, R.O.C.

TEL: 886-3-4690038 FAX: 886-3-4697532

E-mail: [tstsales@mail.taisaw.com](mailto:tstsales@mail.taisaw.com) Web: [www.taisaw.com](http://www.taisaw.com)

## SAW Resonator 644.873 MHz

MODEL NO.: TC0532A

REV. NO.: 2.0

### A. FEATURES:

1. 1-Port Resonator.

### B. MAXIMUM RATING:

1. Input Power Level: 0 dBm
2. DC voltage: 3 V
3. Operating Temperature: -40°C to +85°C
4. Storage Temperature: -40°C to +85°C
5. Moisture Sensitive Level: Level 1 (MSL1)

RoHS Compliant  
Lead free  
Lead-free soldering

### C. ELECTRICAL CHARACTERISTICS:

Characteristic	Units	Minimum	Typical	Maximum
Center frequency <b>Fr</b>	<b>MHz</b>	644.843	644.873	644.903
Insertion Loss <b>IL</b>	<b>dB</b>	-	1.36	2.0
Equivalent Elements				
Motional capacitance <b>C1</b>	<b>fF</b>	-	1.29	-
Motional inductance <b>L1</b>	<b>μH</b>	-	47.3	-
Motional resistance <b>R1</b>	<b>Ohm</b>	-	16.0	-
Parallel capacitance <b>Co</b>	<b>pF</b>	-	2.68	-
Temp.coeff.	<b>ppm/c*2</b>	-	0.032	-
Turnover To	<b>deg.C</b>	-	25	-
Package size		SMD 3.0X3.0X1.4mm		

### D. EQUIVIRENT CIRCUIT:

One-Port Resonator:

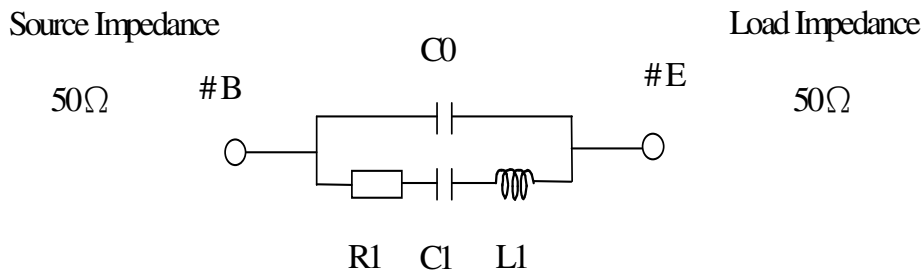

**E. OUTLINE DRAWING:**

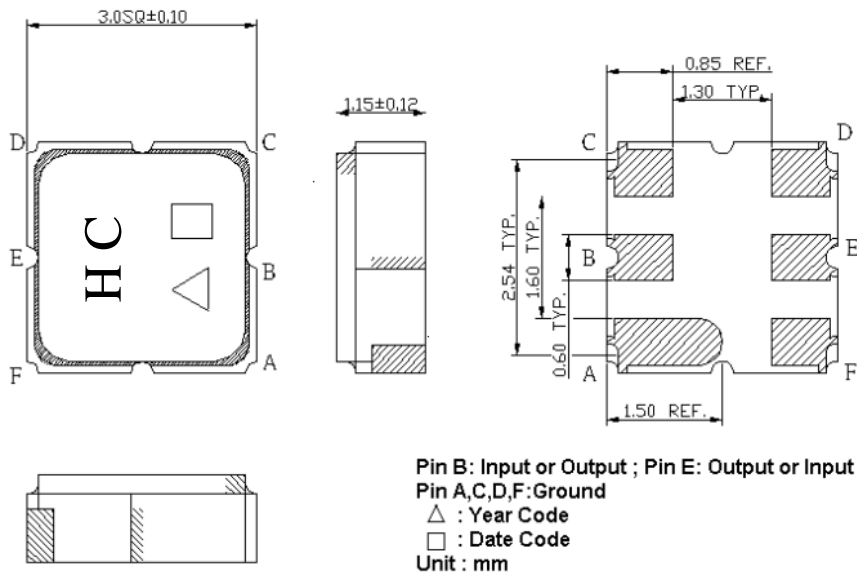

Date code: Provided by planer each year  
 Year code: 9 for 2009, 0 for 2010, ..., 9 for 2019

**F. FREQUENCY CHARACTERISTICS**

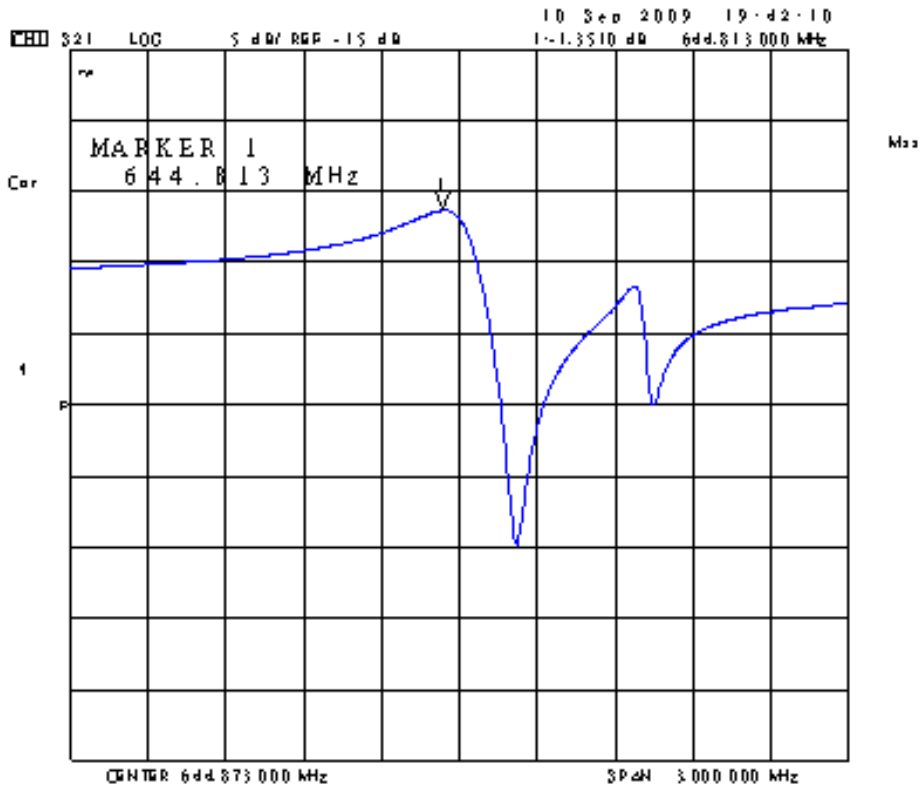

### G. TEST CIRCUIT:

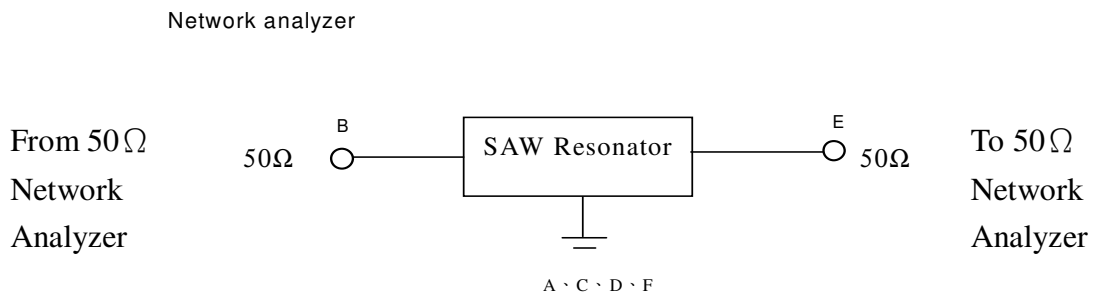

### H. LAND PATTERN:

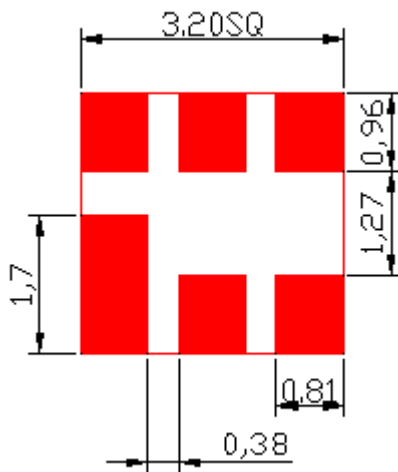

I. PACKING:

1. REEL DIMENSION

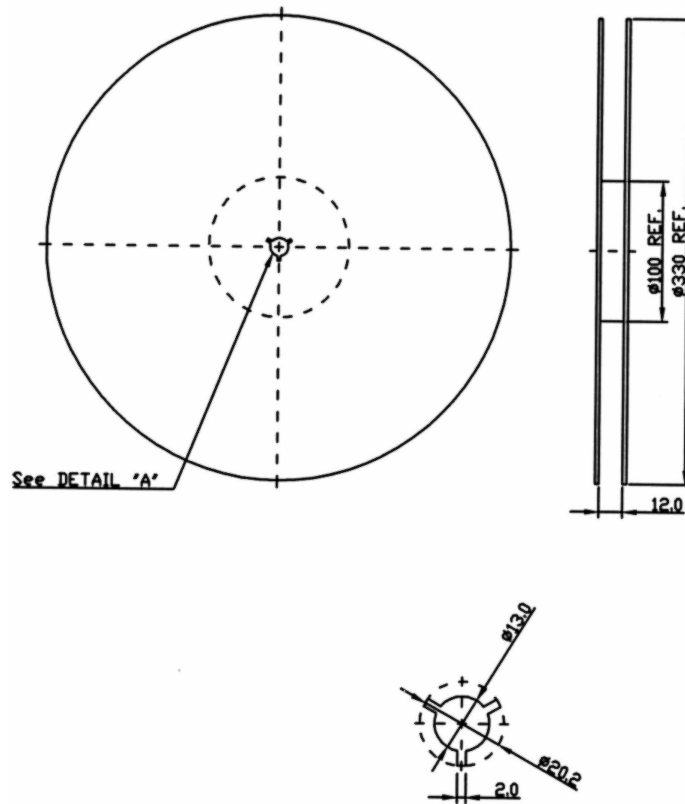

2. TAPE DIMENSION

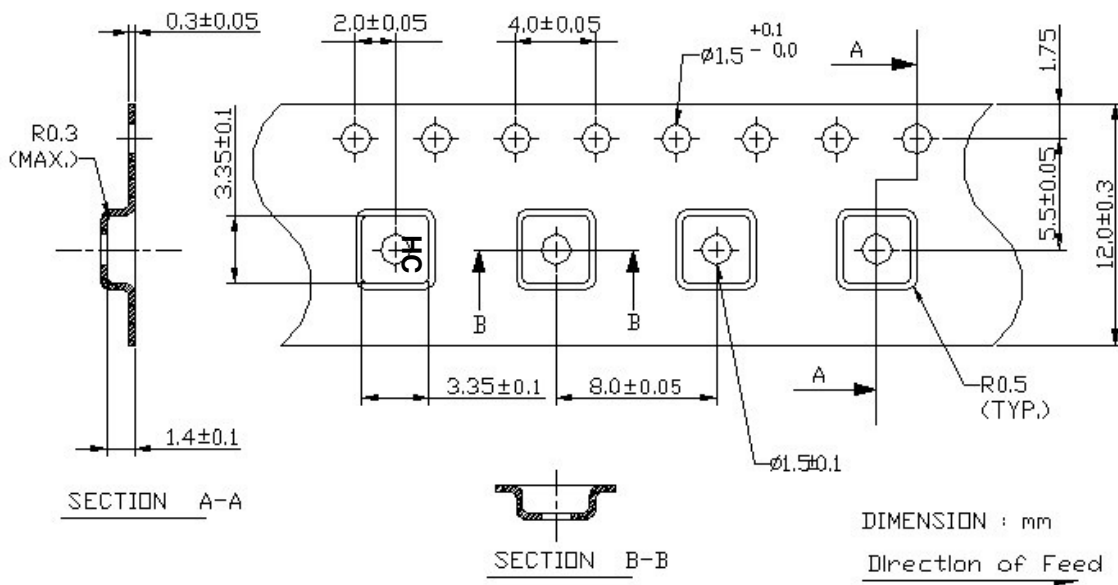

**J. RECOMMENDED REFLOW PROFILE:**

